

Stamford Downtown INVASION!
Art in Public Places
Stamford Downtown
Summer 2019

Application Deadline: February 15, 2019

Each year Stamford Downtown hosts a distinguished outdoor sculpture exhibit designed to attract both local and regional audiences. It has been our privilege in years past to work with more than 300 talented artists to produce CowParade Stamford (2000), ART-o-Mobiles (2001), Stamford Safari (2003), It's Reigning Cats & Dogs (2010), Horsin' Around in Stamford Downtown (2012) Street Seats in Stamford Downtown (2014), Dinosaurs Rule! (2015) and ArtShapes (2017). These engaging exhibits were an enormous success attracting thousands of people to the downtown during the summer to see the beautiful sculptures that showcased the breadth of talent in our local art community.

Stamford Downtown will once again bring the talent of the art community into the downtown for this year's outdoor art exhibit, *Stamford Downtown INVASION!* Artists are invited to submit designs for the Invasion, which will be on exhibit all summer in Stamford Downtown. Design submissions will be reviewed by a jury, which will select a pool of final designs for sponsor review and selection. The pieces will arrive as unpainted fiberglass sculptures ready to be transformed by selected artists. At the end of the exhibit, the pieces will be auctioned and a portion of the proceeds will go to a charity, yet to be determined. To date, our previous events raised over a half a million dollars for selected charities.

Stamford Downtown is accepting proposals from artists who wish to participate in this public art event. Artists whose designs are selected by a sponsor for exhibition will be provided with a blank piece to paint, decorate, sculpt, etc. One week after the opening of the exhibit, each artist whose work is on display will be paid a \$1,500 honorarium.

Specifications

The pieces are made of a layered laminate construction over an interior structure with a mixture of resin and glass fibers in overlapping 1/4" and 1/2" lengths, with the outside layer being a sandable microsphere filled resin surface and primer coated with a white exterior grade sandable primer. All resins and paints are low odor and low VOC formulas which are friendlier to the finishing artists and environment.

Artistic Designs

The artist may paint, sculpt, transform and adorn the pieces as they wish, but the structural integrity of the pieces must not be compromised, and the mechanisms for attaching the pieces to its concrete bases cannot be altered or obstructed.

The viewing public will have full access to the pieces, 24 hours a day, seven days a week. Therefore, pieces should be designed and executed with public accessibility, safety, weather and possible vandalism taken into consideration. In past year's artists have used standard art acrylic paints and primers and varnishes to finish the sculptures. However,

easily damaged materials, like fabrics and papers, as well as items that are easily removed, should be strictly avoided.

The pieces can be painted in an endless variety of patterns, colors and finishes. Artists can use mosaic tiles, wood, tin and other materials. The pieces can be reshaped. Stamford Downtown and the public will delight in these flights of fancy. **However, you may not use perishable materials, like cotton, tulle, feathers, and velvet, which have proved to be subject to the elements and vandalism.** *Stamford Downtown INVASION!* submissions must be of durable materials. In addition, if an artist is sculpting or otherwise decorating a piece, a narrative of the durability of this design must be included.

As shown on the application outline drawing, pieces are available in three different forms. All modifications to this model must be indicated on your application. Artists are encouraged to go wherever their imaginations may take them. As has been true with our previous exhibits, play on words is important and adds to the excitement of the design.

Guidelines

Please remember that the audience will be broad-based and of all ages. Designs that are of a religious, negatively political, racially denigrating, or sexually explicit nature will not be accepted. The use of corporate logos and trademarks are not permitted.

The pieces will be primarily placed outdoors and in areas fully accessible to the public. This means that weather, vandalism, touching, feeling, and even climbing upon the Shapes should be considered. Please keep durability and public safety in mind with your designs.

Selection Process

Artists may submit up to four designs, and will be paid the honorarium for each design selected for production that yields a finished, approved piece for final exhibition.

The selection jury will consist of noted members of Stamford's art/cultural community. The jury will review all the applications received before the submission deadline. Those artists whose designs were not selected by the jury will be notified by mail.

The approved designs will be presented to the exhibit sponsors who may select designs from among these submissions, or may directly commission work from artists of their own choosing. Once a sponsor selects a design for production, the artist will be notified immediately. Please bear in mind, that the sponsor selection process will be ongoing, so artists may have as much as 6 weeks or as little as 2 weeks to finish their sculptures.

Production of *Stamford Downtown INVASION!*

Artists may execute their designs in either their own studios or in studio spaces accessible to the public, located in Stamford Downtown. These public studios will showcase area artists as they execute their product. The artists who have worked in the public studios in past years enjoyed the camaraderie. If you prefer to work in your own studio, you must

arrange your own transportation to get the unpainted piece (s) to your studio and likewise, the finished product, back to Stamford Downtown's designated warehouse.

After artists have completed their pieces, Stamford Downtown will inspect them. If Stamford Downtown determines that an artist's finished piece has been completed in substantial conformity with the artist's approved design, that piece will be deemed approved. Because of the time required for execution and installation, artists must finish their pieces(s) for inspection no later than **May 14, 2019**.

Stamford Downtown will install and remove the pieces from their display bases. Artists should be available for touch up and repair as necessary during the course of the exhibit.

Rights and Entitlements

By submitting your application forms, you confirm that:

1. You are the original creator of your design.
2. You have not copied anyone else's original work.
3. Your design does not infringe on anyone else's intellectual property rights (for example: trademark, trade dress, or design patent.)
4. To the extent that anyone else has contributed to your design, you shall obtain a signed agreement from that person assigning all of their rights in their contribution to you.

As part of the application process, you must sign the Copyright Assignment that accompanies this application. By signing, dating, and returning this Assignment, you are indicating your understanding that you are assigning the entire right, interest, and title to your design(s) to *Stamford Downtown INVASION!*, Stamford Downtown Special Services District. Please keep a copy of these forms for your records.

Within one week of the opening of the exhibition each artist whose work is displayed and whose paperwork is final and complete will receive a \$1,500 honorarium. Stamford Downtown will own the entire right, title, and interest in your design proposal, accompanying sketch, and derivative works, including the final work on the completed piece. You will be acknowledged as the artist on a tag attached to the base of the Shape and in all appropriate publications. However, the sculpture, the copyrights, including the rights to reproduce your design, create copies or reprint your design in books, will be owned by the Stamford Downtown Special Services District.

How to Apply

Please send in the completed application form, your proposed design(s), your resume, and the signed Copyright Assignment by the deadline of February 15, 2019 to:

Kate Cook
Art in Public Places
Stamford Downtown
Five Landmark Square, Suite 110
Stamford, CT 06901

Timeline

Application Submission Deadline	February 15, 2019
Judges panel	February 21, 2019
Sponsor Review	February 22 – April 1, 2019
Artist notification	February 22 – April 1, 2019
Delivery from fabricator	March 2, 2019
Pieces available for artists	March 3 – April 6, 2019
Deadline for finished piece and delivery	May 14, 2019
Installation	May 30-June 2, 2019
Opening Night	June 12, 2019
Prepare and repair for auction	September 5-29, 2019
Auction	October 3, 2019

The exhibition will open on June 2019 and will run through August 2019.

Eligibility

Stamford Downtown INVASION! is open to all artists.

Contact

For more information on *Stamford Downtown INVASION!* and the solicitation of artists and designs, please visit our website at www.stamford-downtown.com or email events@stamford-downtown.com

Stamford Downtown Special Services District
Five Landmark Square, Suite 110
Stamford, CT 06901
203-348-5285

**Stamford Downtown INVASION!
Art in Public Places
Stamford Downtown
Summer 2019
Call For Artists**

Application Deadline: February 15, 2019

Application Form

Please Remember:

Designs that are of a religious, sexually specific, negatively political, or racially denigrating nature will not be accepted. Use of corporate logos and trademarks is not permitted. Durable materials and substantial execution techniques are required.

Please type or print clearly:

Mr. / Ms. First _____ Last _____

Email Address: _____

Mailing Address _____

City, State, Zip _____

Daytime phone _____ Mobile phone _____

- I would prefer to work in Stamford Downtown's public studio space.
- I will transport the piece to and from the studio to my own workspace.

Renderings

You must complete your proposed design on the provided rendering forms. You may copy the outline as needed. The more complete your design rendering, the easier it will be for the panel to review your submission. Please note that all sculptures will have a center pole (not pictured). You may or may not incorporate the pole into your design.

Artist statement:

Please attach a brief description of each piece design, its inspiration, and its proposed execution techniques and materials.

Design #1

Title: _____

Piece Form Preference: Rocket UFO crash UFO Beam

Design #2

Title: _____

Piece Form Preference: Rocket UFO crash UFO Beam

Design #3

Title: _____

Piece Form Preference: Rocket UFO crash UFO Beam

Design #4

Title: _____

Piece Form Preference: Rocket UFO crash UFO Beam

Please select one of the following options:

- Enclosed is a self-addressed stamped envelope to return my renderings in the event they are not selected.
- I authorize Stamford Downtown to discard my materials.

If your design is not chosen, the copyright, interest and title to the design reverts back to the artist.

Assurances and Terms

By signing this application, I agree to all of the terms of the attached request form proposals, and all such terms are hereby incorporated into this application. I certify that all statements made in this application are true to the best of my knowledge. I acknowledge that the Stamford Downtown Special Services District is not liable for damage or loss of materials submitted.

Signature of Artist

Date

Application Checklist

- 1 copy of Application pages 1 & 2
- 1 copy of one-page artist resume
- 1 original signed Copyright Assignment
- 6 color copies of each design on Artist Rendering Form
- Artist Statement for each design

**Copyright Assignment for *STAMFORD DOWNTOWN INVASION!*
Art in Public Places, Stamford Downtown 2019**

I, _____ (artist name), of _____
(artist address), am the creator of the design and sketches of the attached application, which has been submitted to the Stamford Downtown Special Services District, located at 5 Landmark Square, Suite 110, Stamford, CT 06901 (the “District”).

I understand and acknowledge that by submitting the attached design and sketches, the District will own the entire right, title and interest in and to the submitted design and sketches, including but not limited to all derivative works created therefrom, including any finished sculptures.

I understand and acknowledge that if the design and sketches are approved, I shall apply that design to the provided sculpture.

I understand and acknowledge that upon completion and initial exhibition of the finished sculpture in accordance with the Request for Proposals and Application, the District shall pay me an honorarium of \$1,500.00. I desire to transfer all right, title and interest in and to the design and sketches, as well as the finished sculpture, to the District;

I hereby assign to the District all of my right, title and interest in and to the design and sketches, and any finished sculpture created therefrom together with any and all rights of copyright.

I acknowledge and agree that due to the nature of the public display of the finished sculpture, the District shall not be liable for any distortion, mutilation, modification or destruction of the finished sculpture by any accident, act of God or person. I hereby waive my rights under the Visual Artists Rights Act (VARA), 17 U.S.C. 106A, as against the District in the event of such distortion, mutilation, modification or destruction.

I further acknowledge and agree that if the finished sculpture is vandalized, damaged or otherwise modified and I am unable or unwilling to promptly repair such alteration, the District shall have the right to make, or have made, such repairs, even if the repairs constitute a distortion, mutilation or modification under VARA. I hereby waive my rights under VARA in the event and to the extent the District deems such repair necessary.

I hereby swear that I am the sole author of the designs and sketches and that the design and sketches are an original work of authorship, which does not infringe upon the copyright rights or any intellectual property rights of others, and that I have the unencumbered right to make this assignment.

Signature: _____

Printed Name: _____

Date: _____

ROCKET

Design Title:

Artist Name:

Materials:

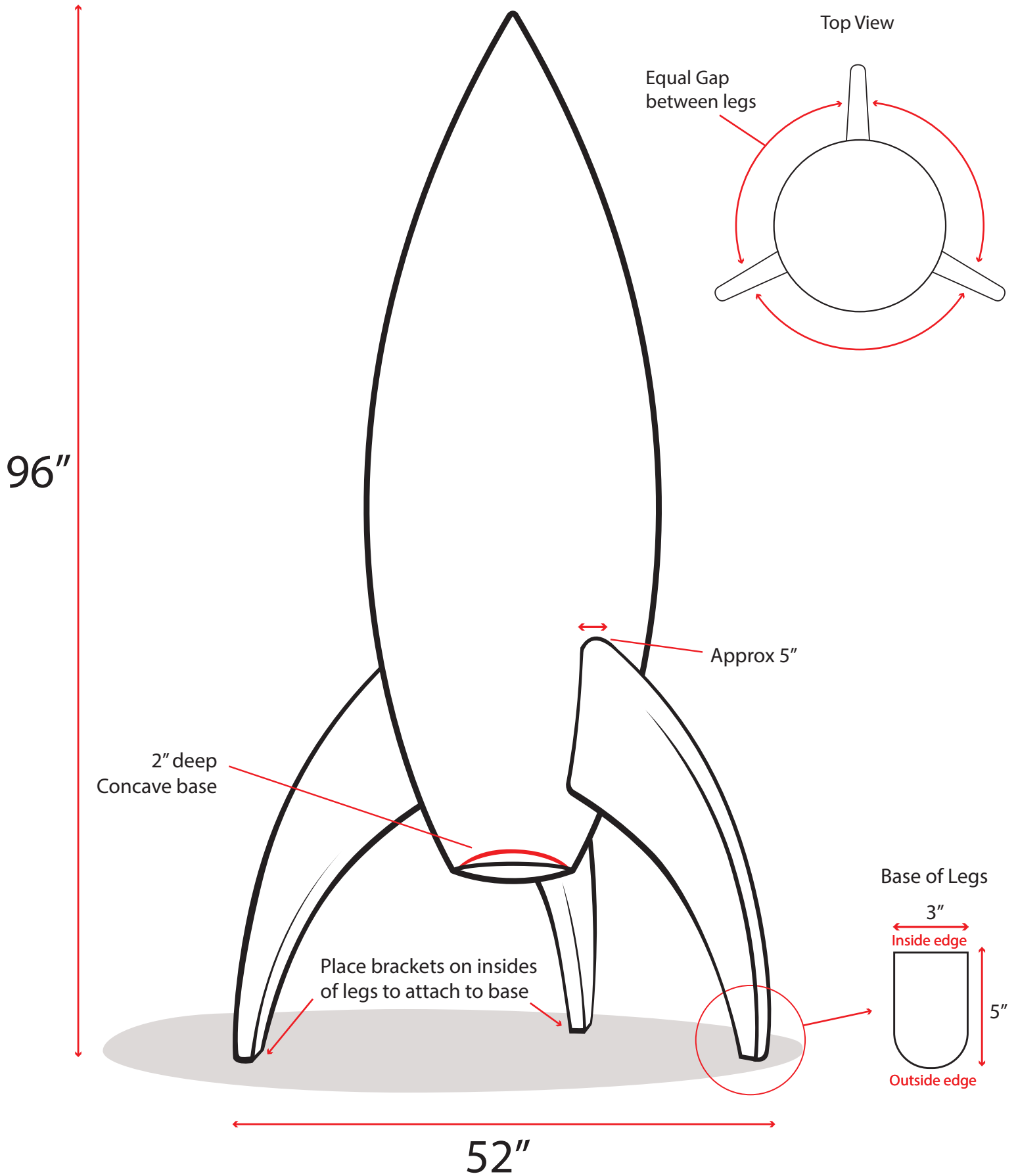

UFO BEAM

Design Title:
Artist Name:
Materials:

76"

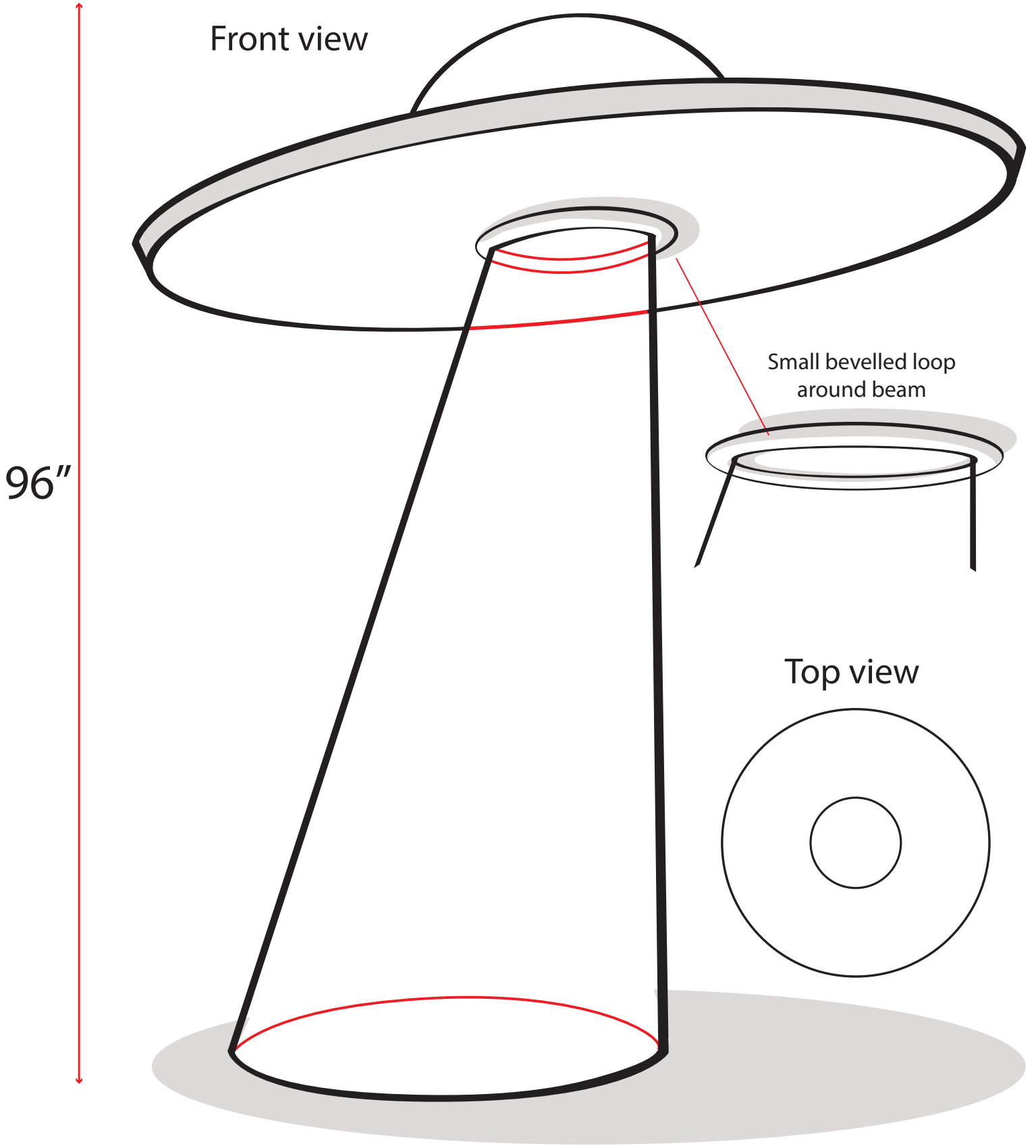

Back view

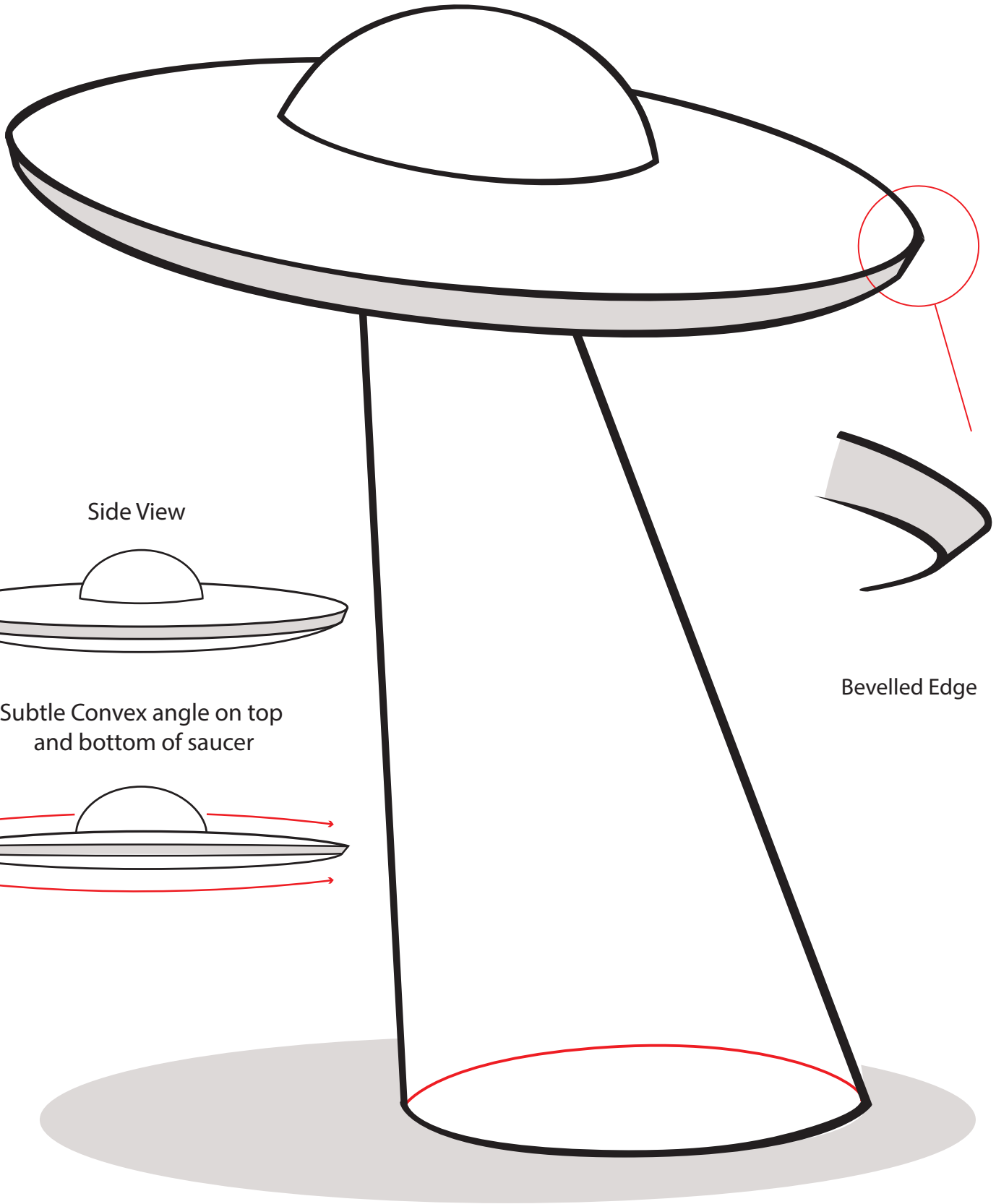

Side View

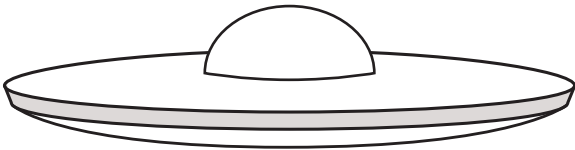

Subtle Convex angle on top
and bottom of saucer

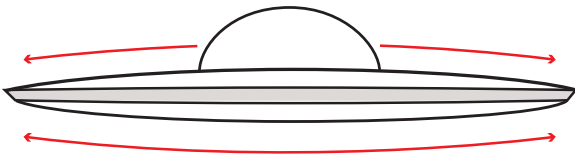

Bevelled Edge

UFO CRASH

Design Title:

Artist Name:

Materials:

Front view

96"

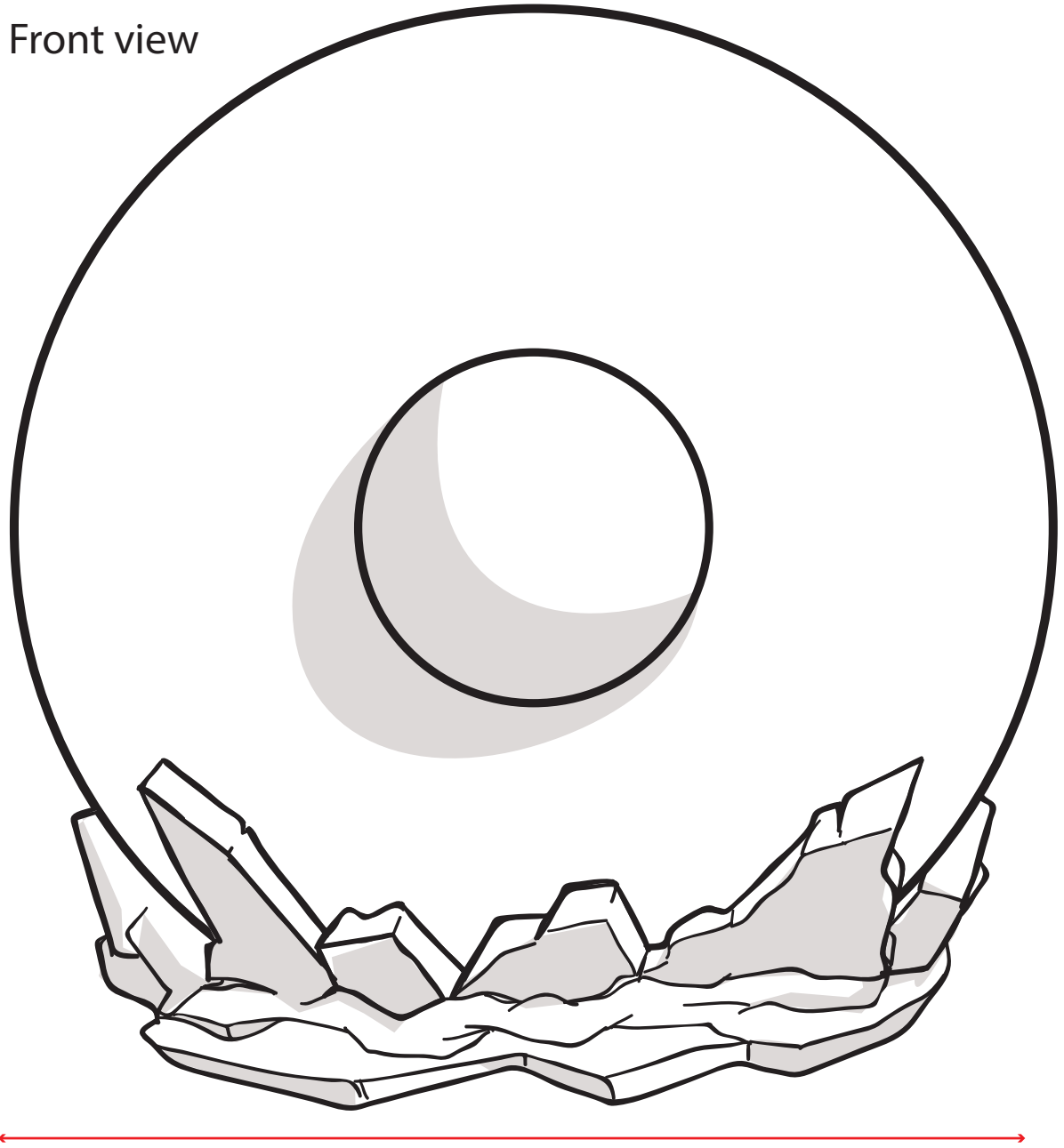

76"

Side view

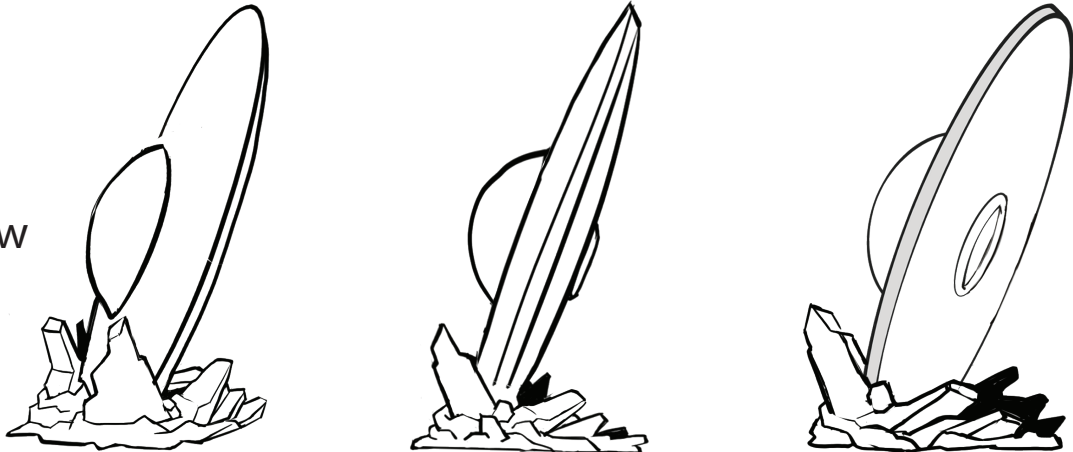

UFO CRASH

Design Title:
Artist Name:
Materials:

